

Falcon LM Series Mortise Trim

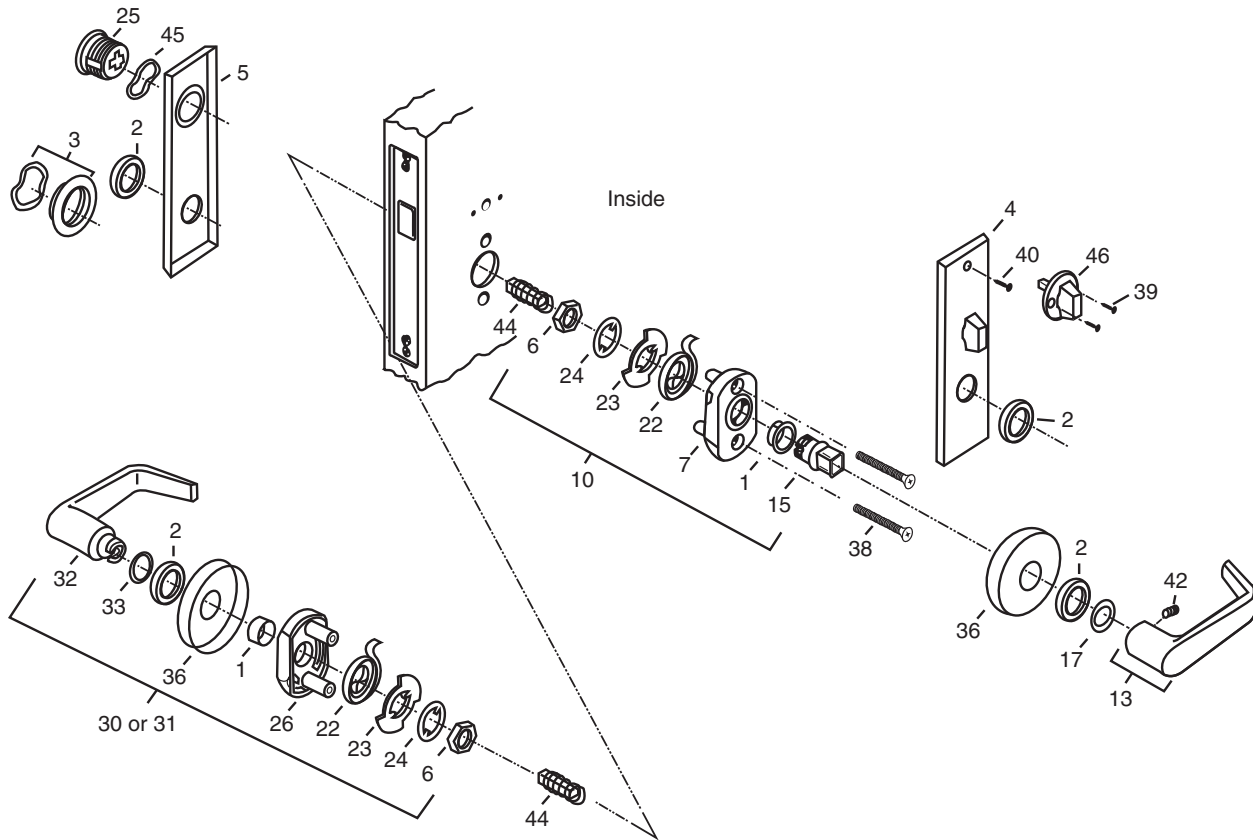

Call Out Number	Description	Part Number
1	Bushing	030067-000-50
2	Collar	030059-000 *
3	Collar Assy, Sectional	A08794-000 *
4	Escutcheon w/T-Turn, Napa	A30203-000 *
5	Escutcheon, Napa	030066-005 *
6	Hex Nut	030282-000-30
7	Inner Insert	030051-001-55
10	Inner Insert Assy	A30073-001-00
13	Inner Lever Assy, Dane (shown)**	A30202-00D *
15	Inner Trim Shank	030053-001-30
17	Inner Washer	030205-001-50
22	Lever Return Spring	030057-002-30
23	Lever Stop	030054-001-30
24	Lock Washer	030284-000-60

Call Out Number	Description	Part Number
25	Mortise Cylinder w/9894-1 Cam	985 w/9894-1
26	Outer Insert, Tapped	030051-000-55
30	Outer Lever Assy, Dane Gala	A30068-00D *
31	Outer Lever Assy, Dane Napa	A30072-05D *
32	Outer Lever, Dane	021280-000 *
33	Outer Washer	030205-002-50
36	Rose	030052-000 *
38	Screw, 10-32 x 2 FHMS	030069-032-30
39	Screw, 6 x 1/2 FHSMS	002073-000 *
40	Screw, 6 x 3/4 OHSMS	002074-012 *
42	Set Screw, 1/4-28 x 1/4	030283-004-30
44	Spindle & Spring Assembly	A21245-000-00
45	Spring Washer, Cylinder	008789-001-60
46	T-Turn Assy, Sectional	A20336-000 *

*= Finish or Specify Finish on All

**For other lever options, see page